



Automation for a Changing World

# Delta Metallurgy Industry Solutions

[www.deltaww.com](http://www.deltaww.com)





Smarter. Greener. Together.

## Who We Are

**Delta is a market leader that has won wide recognition as a:**

- Global power and thermal solution provider, with partners such as Apple, IBM, HP, Lenovo and more; No.1 in Switching Power Supplies since 2002, DC Fans since 2006.
- Leading brand in industrial automation applications for factories, processes, and buildings; with specific system solutions for textiles, packaging, machine tools and more.
- Leading telecom power system provider in Europe, Americas, Asia and emerging markets; in long term partnerships with Vodafone, T-Mobile, Orange, China Mobile, Bharti and more.

## About Delta Industrial Automation

Since the launch of our first AC motor drive in 1995, the Delta Industrial Automation Business Group (IABG) has focused on automation technology with quality, reliability and precision to realize our promise of “Automation for a Changing World”. We provide innovative automation products that include AC motor drives, power quality improvement devices, sensors, and control and motion devices. With enhanced integration and industrial network development, our industrial automation solutions find application in a broad range of machinery, including: metal processing machines used in the food industry, textile industry, chemical industry, electronics industry, plastic industry and more; automation equipment used in the pharmaceutical industry and printing industry; and energy-saving air-conditioning and water supply facilities used in buildings. Our mission is: “To elevate our living environment through advanced automation technology and value added innovation”. With Delta's innovative, reliable, energy-saving automation solutions and rapid global service, we help make the world “Smarter. Greener. Together.” with our partners and customers.

# Table of Contents

Company Introduction	1
Metallurgy Industry Overview	2
Metallurgy Processes and Technology	3
Colored Metallurgy Industry	
Iron and Steel Industry	
Delta's Metallurgy Industry Solutions	5
Applications	14
List of Delta Industrial Automation Products	15

## Industry Overview

Delta Electronics is among the world's leading providers of industrial automation products and solutions. Our mission is to help customers improve their operating performance, system reliability and productivity with energy-saving, high-efficiency, and smart solutions. Delta's metallurgy industry solutions provide client companies with a highly effective means for lowering their energy consumption and environmental impact.

The metallurgy industry is known for its high energy consumption and pollutant emissions. The energy consumption of the metallurgy industry in China accounts for about 10 percent of the country's total energy consumption. In its 12th Five-year Plan, the China government has given a high priority to either eliminating or relocating industries that are high energy consuming or not friendly to the environment. The metallurgy industry is one of the targets for reduced energy consumption based on this plan.

The 12th Five-year Plan Period is a crucial period for boosting industrial transformation and upgrading traditional industries to promote green and low-carbon industrial development. In this period, the generated investments may reach about 2,366 billion yuan (close to 386.68 billion US dollars). Efforts to improve metallurgy's energy conservation and energy efficiency have become more targeted and are yielding positive results for national social and economic development.

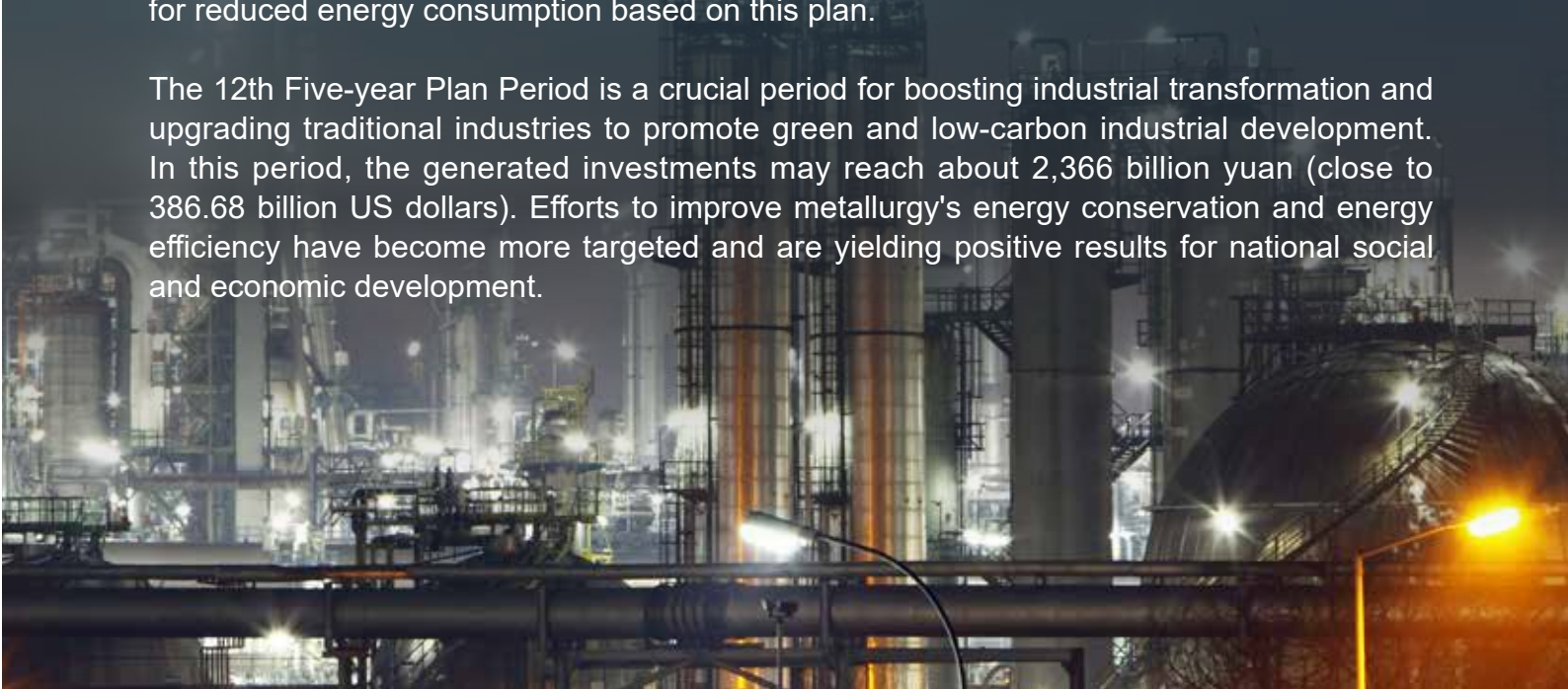



# Metallurgy Processes and Technology

The term "metallurgy" means the technology of metals. In production, metallurgy provides metal components for everyday consumer and various industrial uses. The metallurgy industry involves the exploration and treatment of mined ores, the processes of production and refining of metals and alloys from ores or other materials, and the processes of metal shaping such as: casting, forging, rolling, cladding, extrusion, metalworking and machining.

The metallurgy industry is one of the mainstays of a country's manufacturing sector, and plays a very important role in the economic development of the country at large.

## Colored Metallurgy Industry

Colored metallurgy includes the production of heavy nonferrous metals (copper, nickel, tin, lead, zinc), light metals (aluminum, magnesium), small metals (cadmium, cobalt, mercury), precious metals (gold, platinum, silver), and rare metals (lithium, titanium, selenium). In a word, colored metals are all metals other than iron, manganese, chromium and their alloys.

Compared to black (ferrous) metals, colored (non-ferrous) metals do not contain iron, so they are not magnetic and have a higher resistance to rust and corrosion. The colored metals have characteristics such as malleability, ductility, elasticity, hardness, brittleness, and conductivity. They are also much lighter and can be hammered and pressed into shape, making them well-suited for use where strength is needed. The colored metals are very important and essential raw materials for modern industries, and are mainly used in the fields of national defense, electronics, electrical wiring and new technologies.

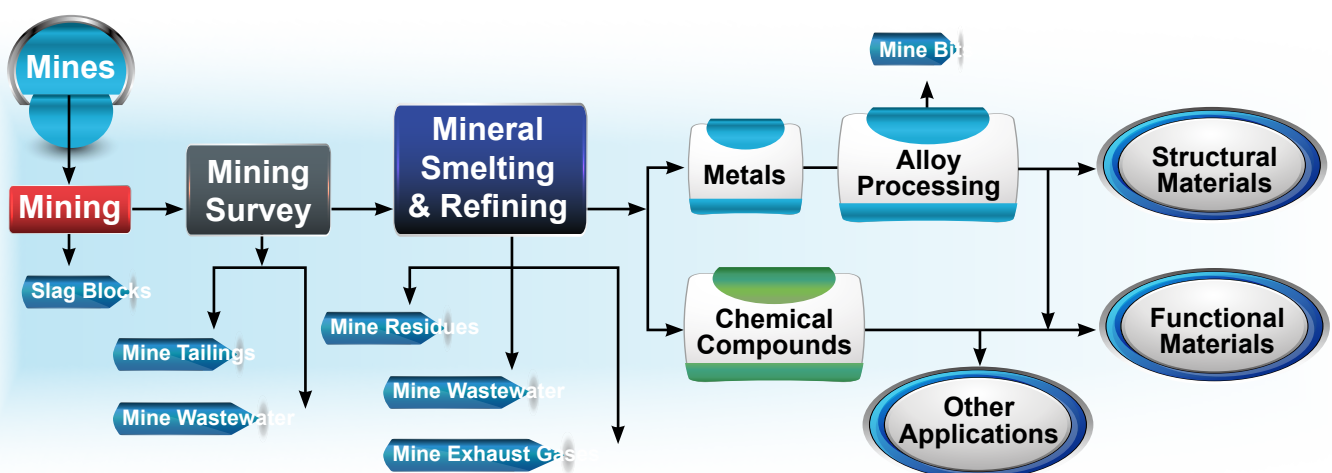

## Iron & Steel Industry

The iron and steel industry is also known as the black or ferrous metallurgy industry. This industry is a basic industry that is an important part of the national economy and plays a crucial role in the development of the country. It is also a significant measure of the level of industrialization and the overall strength of the country.

The development of the iron and steel industry directly affects the metal goods we use in our daily lives as well as those used in industries such as defense, construction, machinery, ship building, automotive, electronics, household goods and many others.

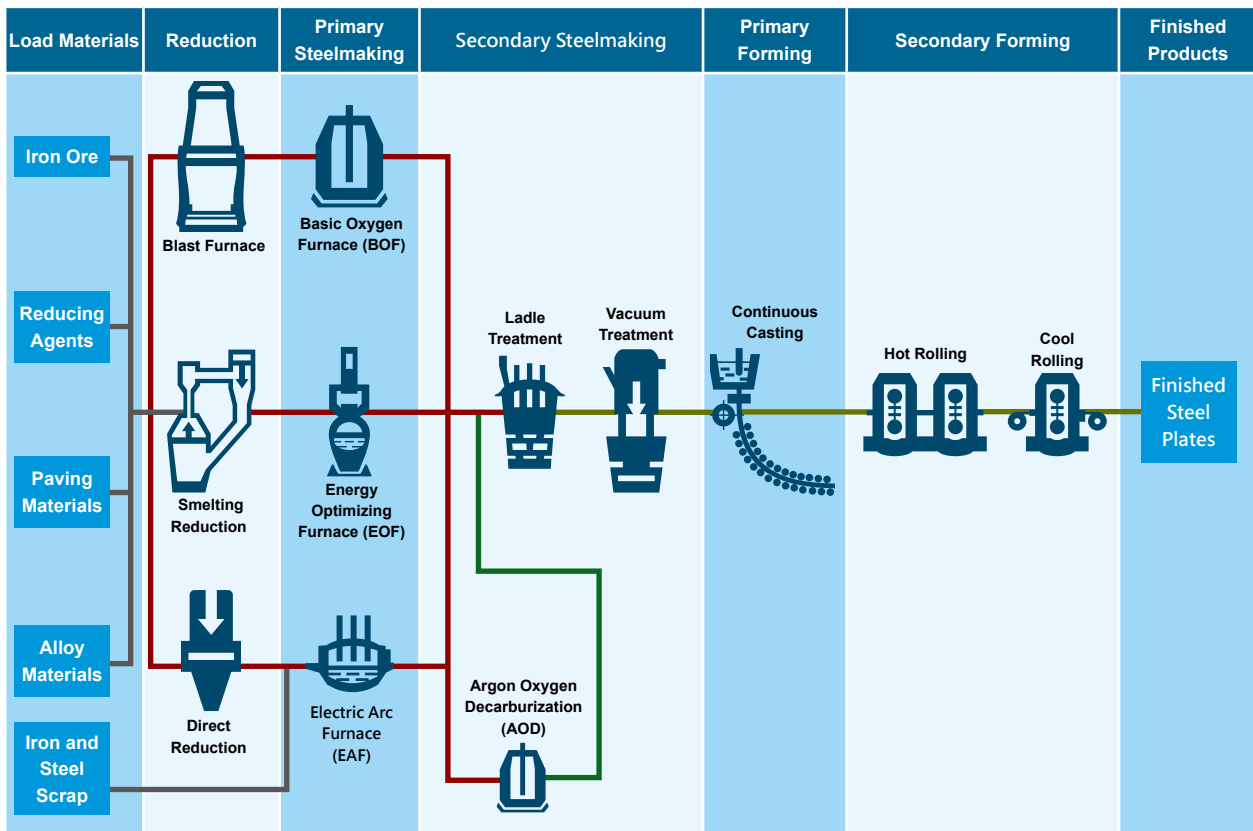

# Delta's Metallurgy Industry Solutions

Delta provides energy-efficient metallurgy industry solutions based on Delta's automation solutions and energy management solutions. The advantages of our integrated automation solutions include full-range organization and functions, easy installation, and affordability.

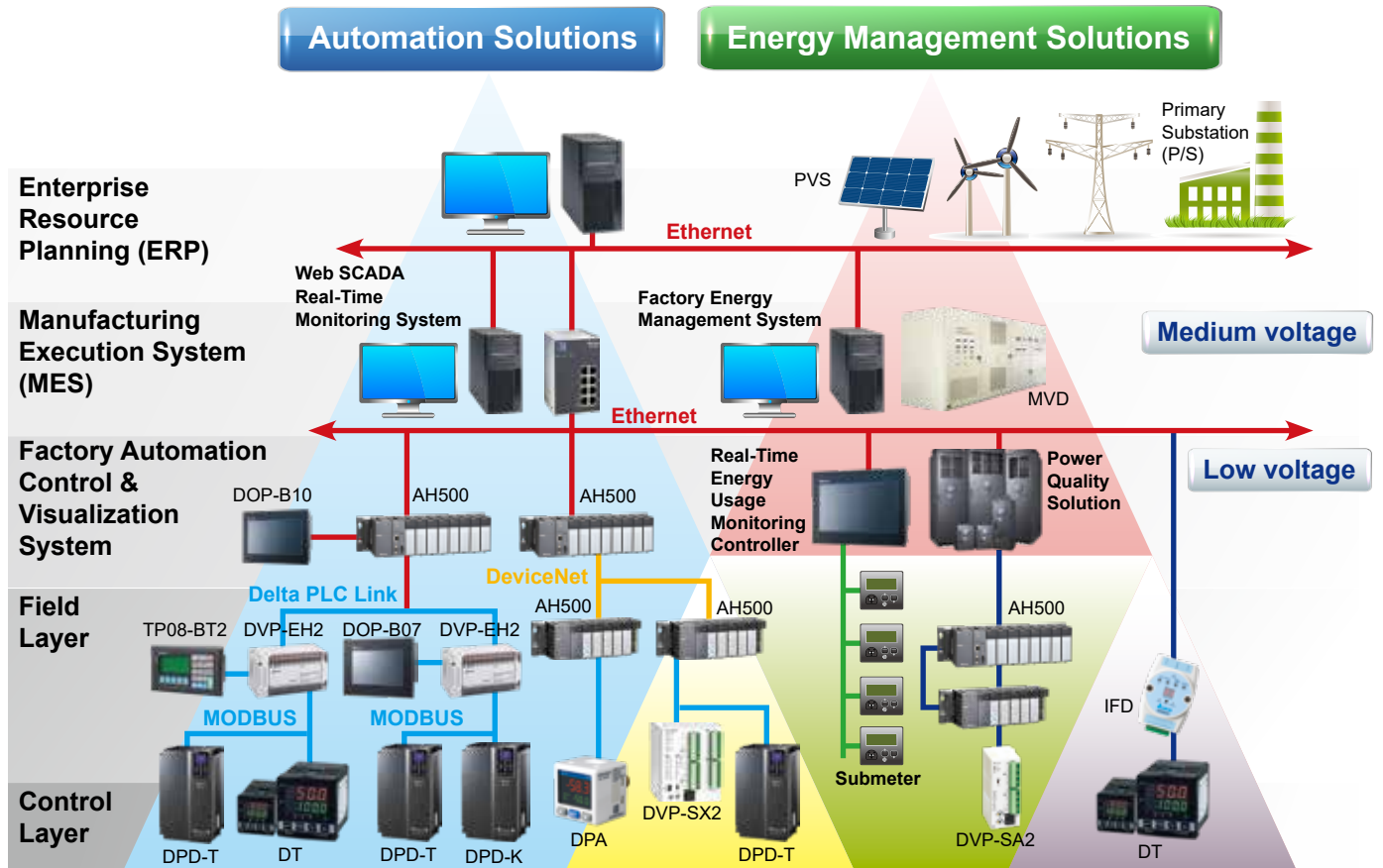



## Field Layer:

The Field Layer uses Delta's C2000 series and CP2000 series control drives with APF / SVG / AFE series power quality improvement products to reduce harmonic waves and optimize power factor. With this system, you can enhance power efficiency for energy savings and make the power grid cleaner and more stable to reduce the risk of electrical accidents.

## Control Layer:

The Control Layer includes Delta's small DVP series and midrange AH500 series PLCs and its temperature controllers to various remote I/O modules. It executes process editing and control via a Delta PLC Link, Ether Link and networking systems such as MODBUS, CANopen and DMCNET to carry out the control and extension of equipment in this Control Layer.

## Information Layer:

The Information Layer adopts Delta's IES series industrial Ethernet switches, IFD series industrial network converters and its DOP-B series HMIs to monitor and conduct remote control. With the aid of eRemote and eServer software, monitoring and managing the system is easy. You can receive complete information from the field and control layers, transmit, backup and analyze the data and control the processes in real-time through the network.

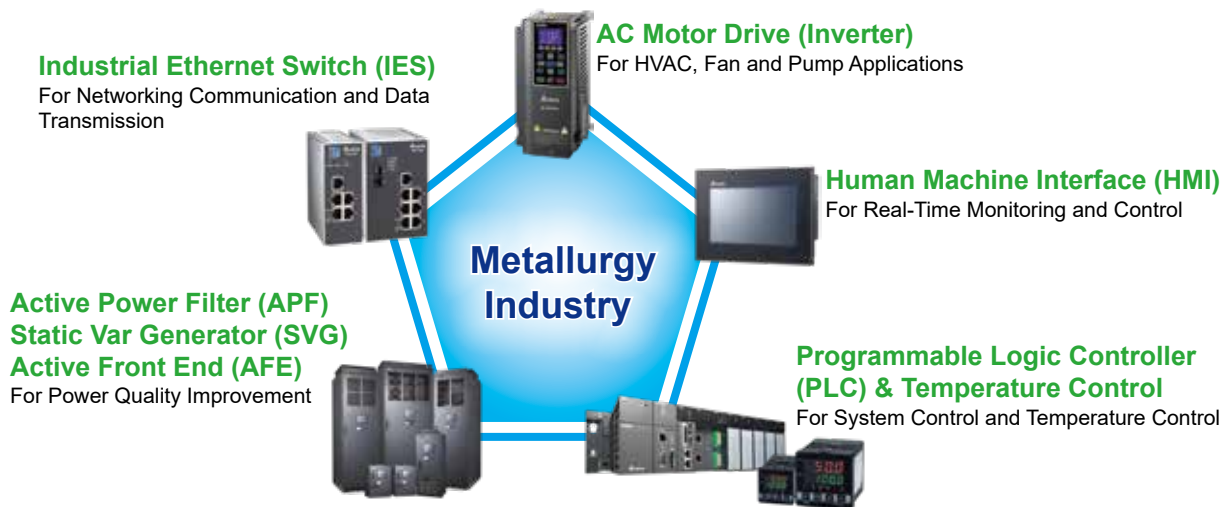

# Variable Frequency Control Solution for Blowers and Water Pumps

Delta's C2000/CP2000 control drives provide outstanding features and benefits especially for equipment such as water pumps and blowers, as listed below.

## Advantages of variable frequency operation:

- ▶ Reduces inrush current for automatic speed adjustment
- ▶ Avoids the impact of starting voltage to grids
- ▶ Protects the electro-mechanics and their peripherals for a prolonged lifespan
- ▶ Decreases the noise interference to equipment during operation
- ▶ Provides flexibility and precision for equipment control

## Benefits of variable frequency operation for blowers and water pumps

- ▶ Improves energy-saving efficiency significantly
- ▶ Reduces the amount of valves needed for simplified pipelines
- ▶ Avoids the water leakage and energy loss caused by the increased pipeline pressure of traditional flow adjustment valves
- ▶ Lowers the pressure caused by the mechanics of blowers, water pumps, pipelines, and ventilation channels



## Delta provides the PIC series integrated solution of stand-alone variable frequency control cabinets

- ▶ Embedded with C2000/CP2000 series control drives
- ▶ Supports multiple communication protocols including MODBUS for easy integration with various building control systems
- ▶ An integrated solution provides clients with a simplified interface with better service





# Delta's Power Quality Solution



**Past**

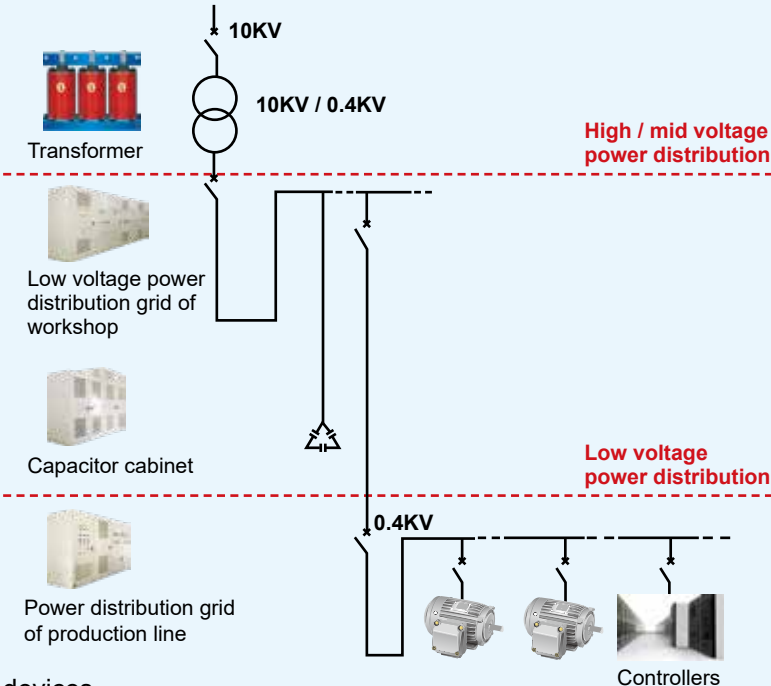

Transformer

10KV

10KV / 0.4KV

High / mid voltage power distribution

Low voltage power distribution grid of workshop

Capacitor cabinet

0.4KV

Low voltage power distribution

Power distribution grid of production line

Controllers

- ▶ Main loads: motors and linear load devices
- ▶ Main power quality problem: static reactive power
- ▶ Solution:

A simple power distribution system using capacitors successfully solves all power quality problems.



**Now**

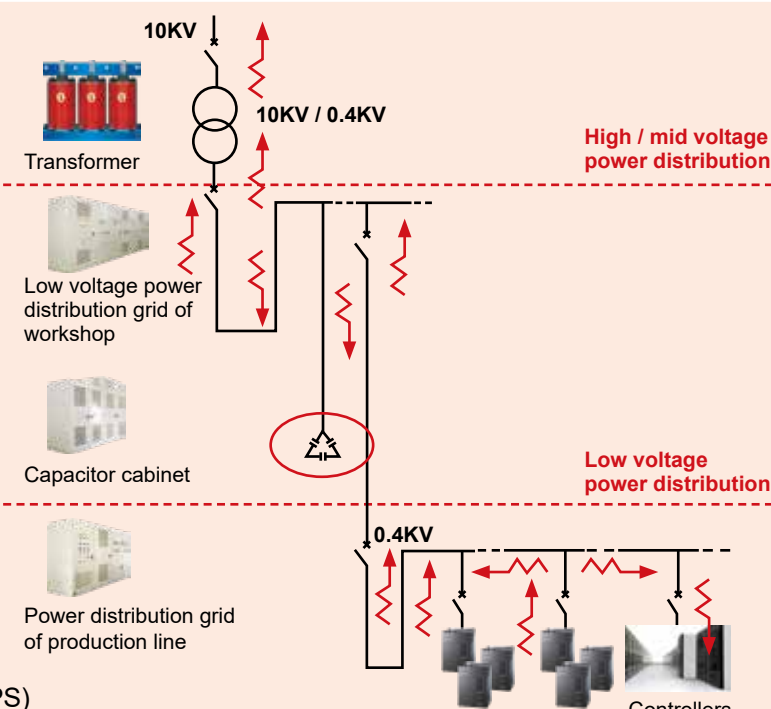

Transformer

10KV

10KV / 0.4KV

High / mid voltage power distribution

Low voltage power distribution grid of workshop

Capacitor cabinet

0.4KV

Low voltage power distribution

Power distribution grid of production line

Controllers

- ▶ Main loads: rectifiers (inverters, UPS)
- ▶ Main power quality problem: harmonics and reactive power
- ▶ Solution:

A more complex power distribution system using capacitors results in new power quality problems.

# Delta's Power Quality Solution

A traditional power quality solution uses capacitors to solve reactive power problems, but this is no longer sufficient for the industrial automation and building automation applications of today.

Recent industrial automation applications adopt AC motor drives (inverters), UPSs, switching power supplies and many other devices that can contaminate the grid with non-sinusoidal current and generate more power quality problems including harmonic distortion and resonance. A system that continues to use capacitors as the only solution will eventually lead to device malfunctions and shortened lifespans.

For power efficiency and a clean grid for today's automation applications, Delta's power quality improvement solutions are your best choice.

## System Structure

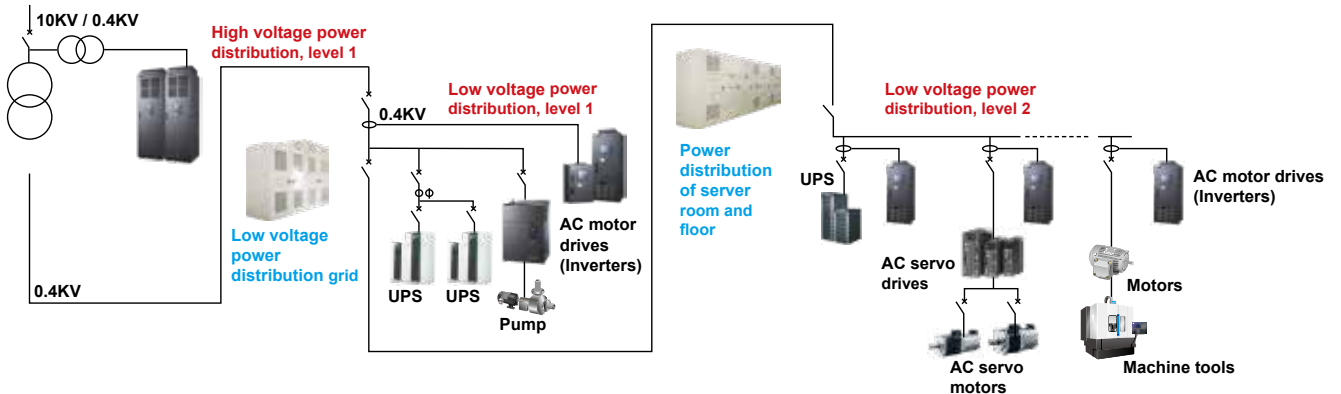

## Active Power Filters - AFE2000 Series

Solutions	High voltage centralized control	Low voltage centralized control	Group control	Individual control
Location	Input side of transformer	Output side of transformer	At different districts or different floors	Install before any device that causes interference
Product	APF2000	APF2000	APF2000	APF2000
Performance	THDI<5% THDU<3% Power factor> 0.96	THDI<5% THDU<3% Power factor> 0.96	THDI<5% THDU<3% Power factor> 0.96	THDI<5% THDU<3% Power factor> 0.96

## Static Var Generators - SVG2000 Series

- ▶ Provides reactive power and harmonics compensation to private low voltage distribution system
- ▶ Available with large capacity
- ▶ Reactive power compensation and filters up to 13<sup>th</sup> order harmonics
- ▶ Provides dynamic and precise compensation to leading & lagging reactive power
- ▶ Replaces or complements the capacitor cabinet

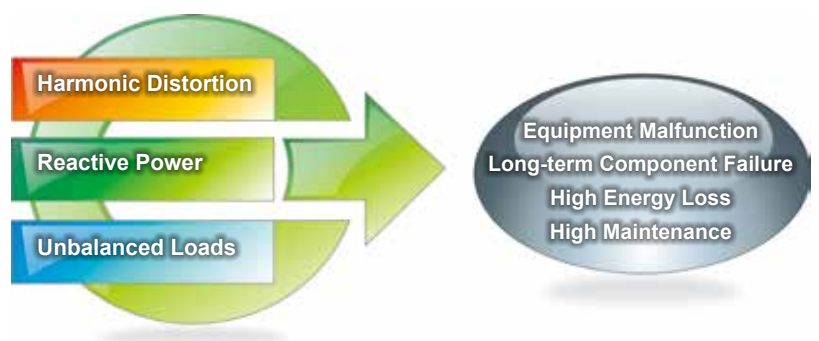



## Integrated Total Solution for the Metallurgy Industry and Metal Market.

With strength in power electronics and extensive knowledge in automation technology, Delta has developed an integrated total solution which includes Delta's PLCs, HMIs, IFD series industrial network converters and IES series industrial Ethernet switches for the metallurgy industry and metal market. This integrated total solution features open networks, reliability, security, cost-effectiveness, and ease of customizing to achieve high plant productivity, high product quality and flexible plant operation.

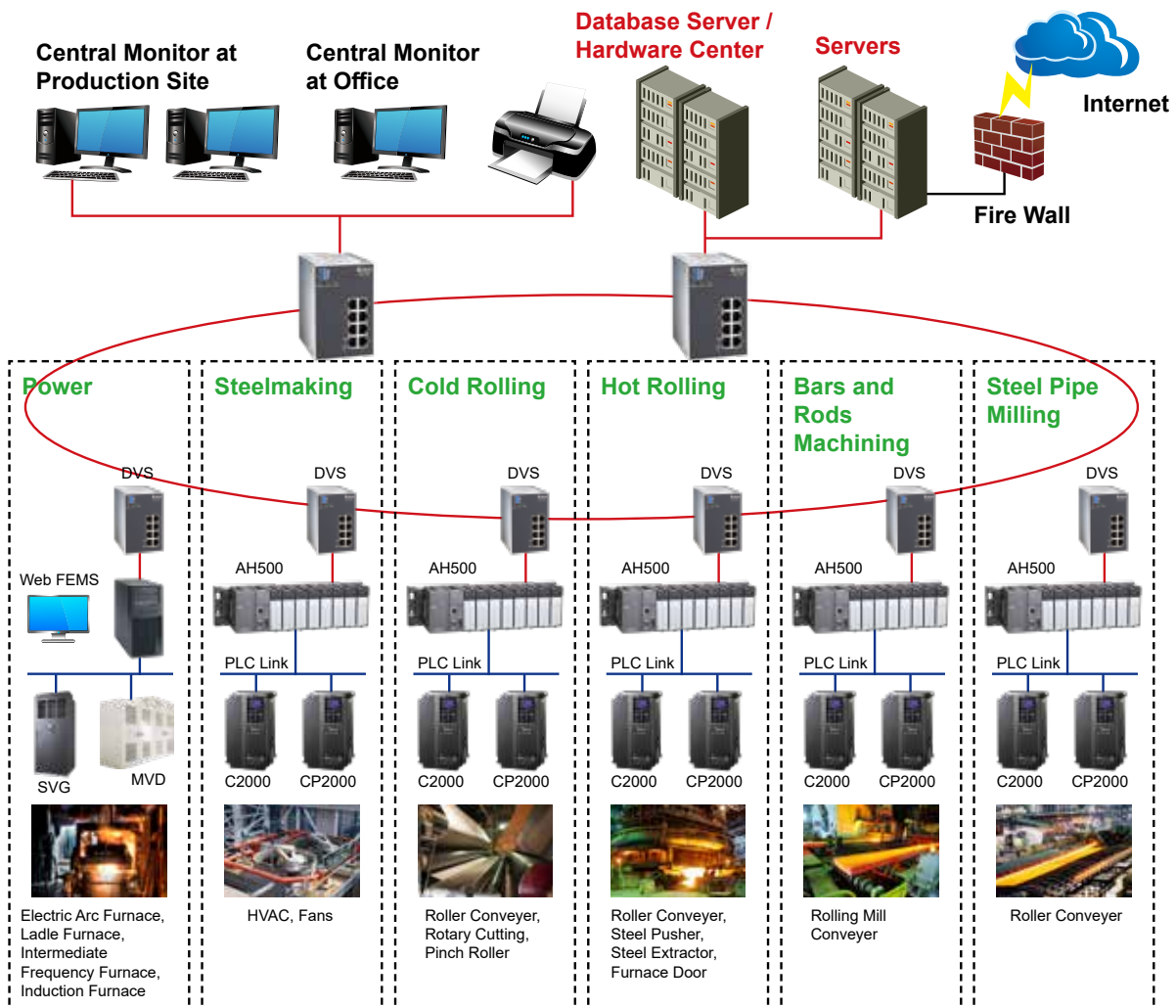



# Automation and Control Solution for Sinter Plants

This solution adopts Delta's midrange AH500 series PLCs in different systems and at different stages to accomplish distributed remote control and centralized management and allow users to easily monitor and control the automation equipment in a sinter plant.

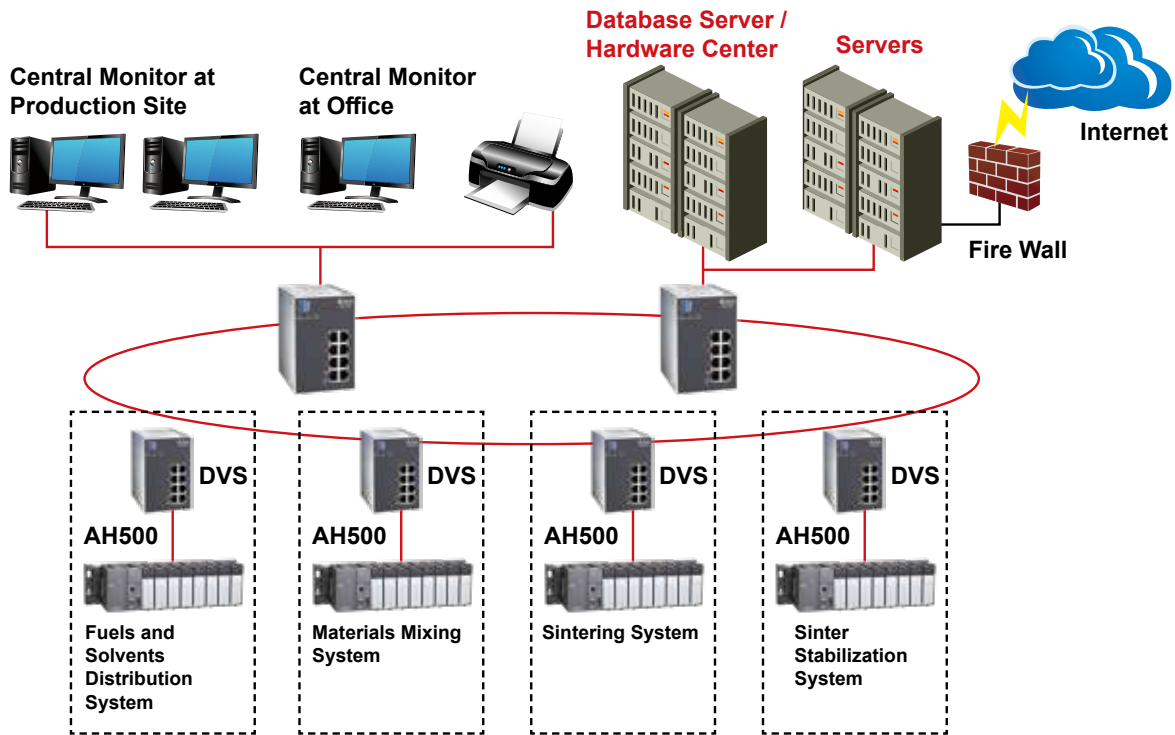

# Automation and Control Solution for Coking Plants

The heart of the process in a coking plant is the coking battery comprised of a number of coking ovens. For enhancing the efficiency and stability of coking ovens and for optimizing the performance of the coking battery, Delta's Coking Plant Automation Solution applies Delta's midrange AH500 series PLCs to provide high speed and stable motion control for ensuring stable and continuous production. The main applications are the coke dry quenching room and the coke oven production system.

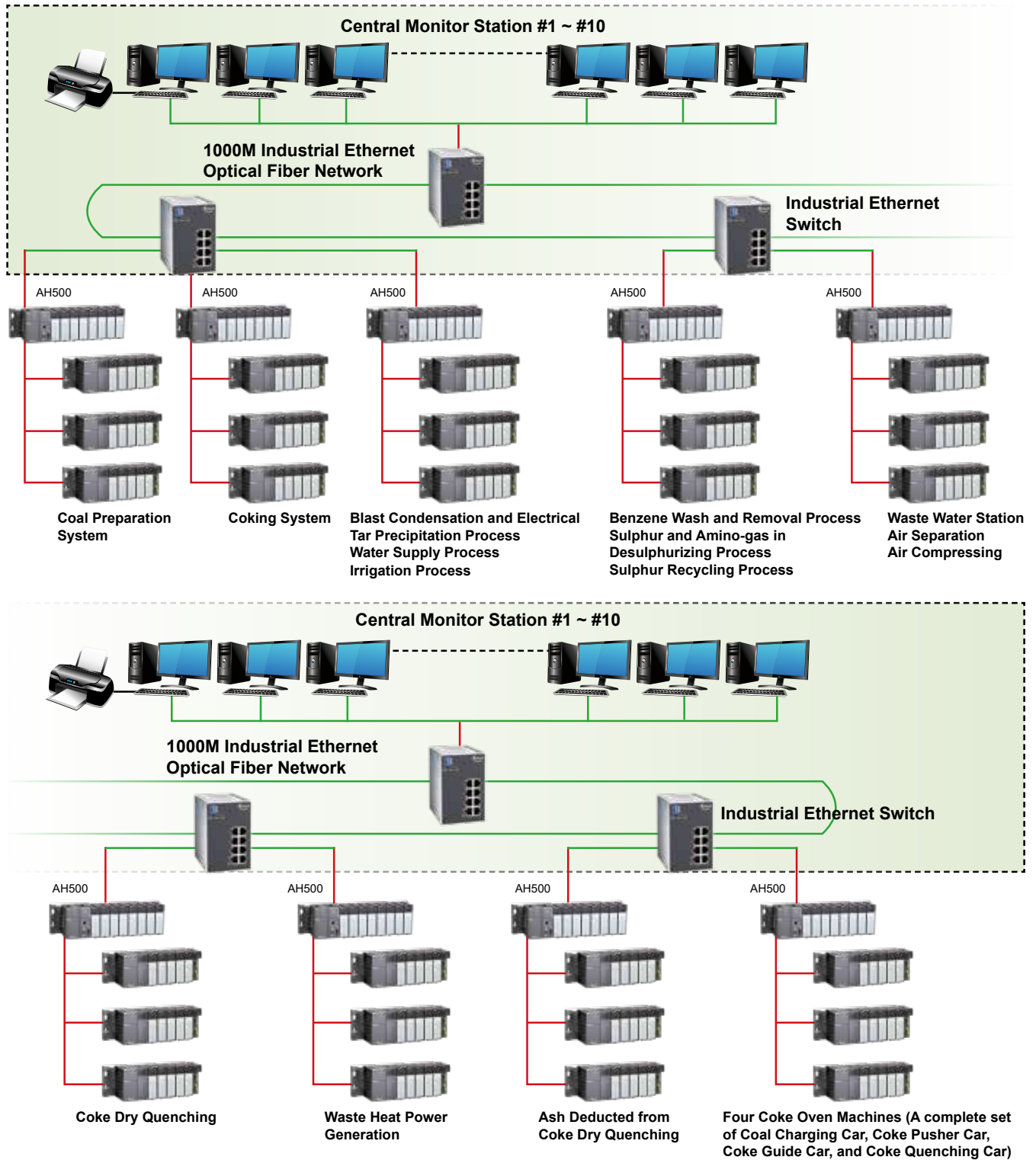



## Automation and Control Solution for Blast Furnaces

This solution mainly consists of a blast furnace control system, materials loading and distribution control system, hot blast stove control system, and bag dust collection control system. The combination of these control systems is to ensure the smooth continuity and real-time monitoring operation of iron making processes in the blast furnace.

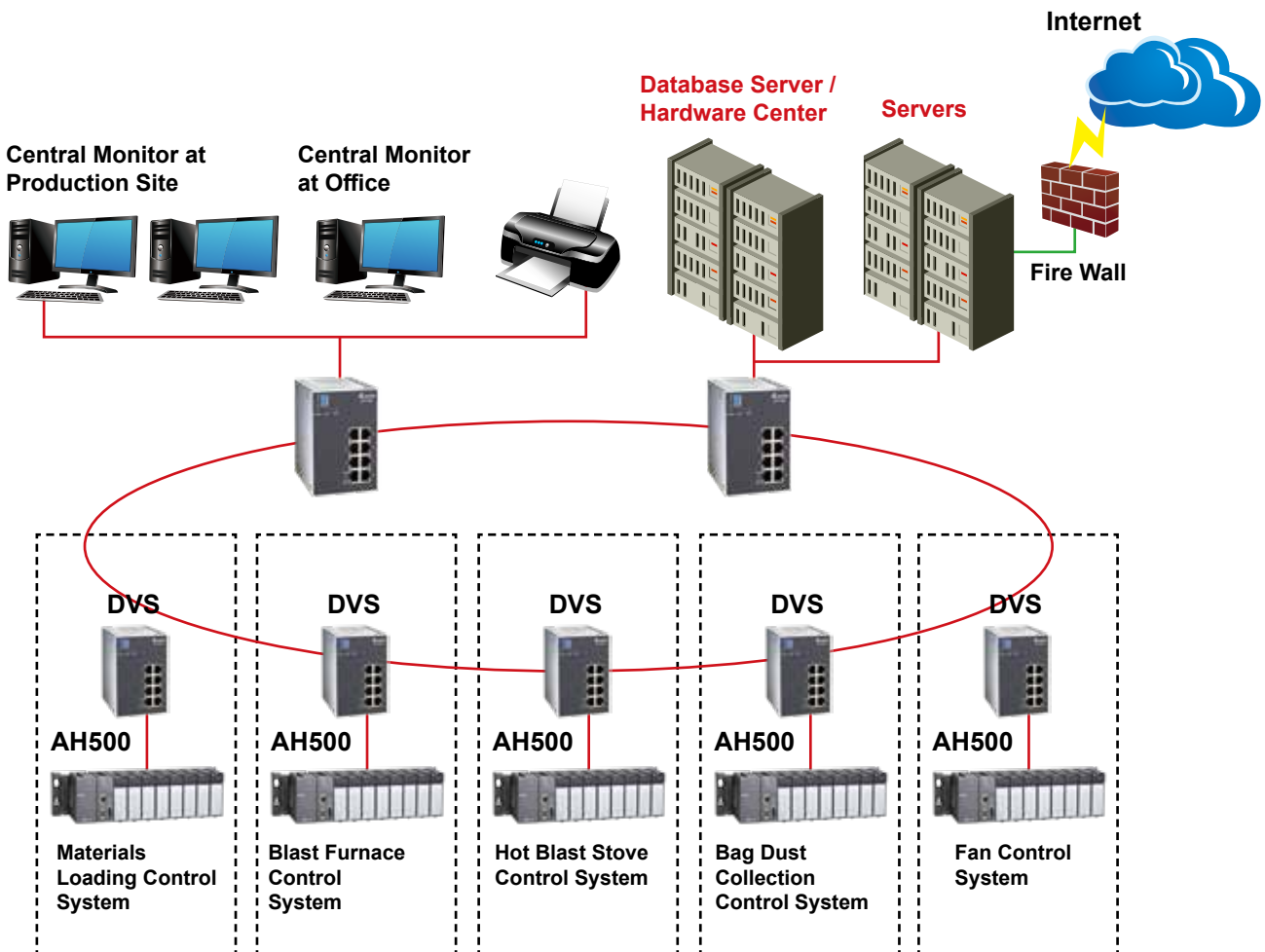





## Applications

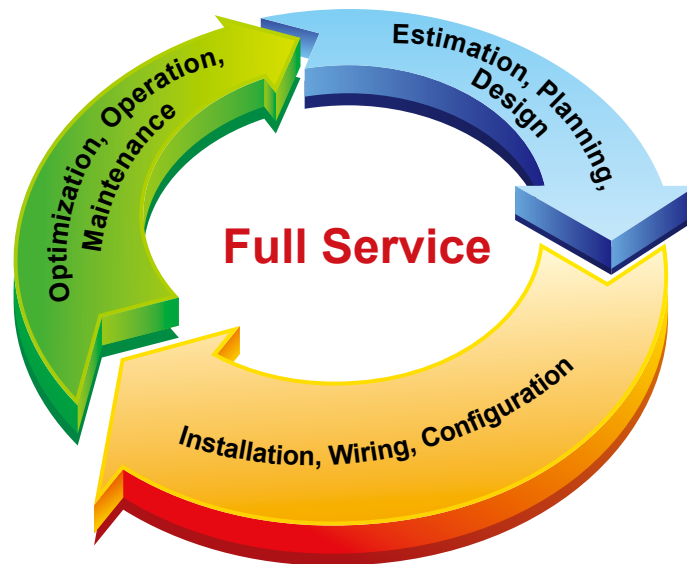

	Process	Applications
<b>Main Processes</b>	Mining	Conveyers, Lifters, Elevators, Crushers, Air Compressors
	Coking	HVAC, Fans, Pumps
	Sintering	Helical Selecting Materials, Belt Feeding Materials
	Ironmaking	Materials Loading Control of Blast Furnaces, Dedusting Fans, Cooling Fans
	Steelmaking	Dedusting Fans, Recycling Fans, Roller Conveyers
	Continuous Casting	Roller Conveyers, Steel Pushers, Steel Extractors
	Rolling (Metalworking)	Steel Plates and Sheets: Heating, Roller Milling, Cutting, Winding
		Bars and Rods: Heating, Wire Drawing, Rotary Cutting, Winding
Power	Pipes and Tubes: Bending, Pulling, Rolling Rolling Mills, Electric Arc Furnaces, Intermediate Frequency Furnaces, Welding Machines	
<b>Auxiliary Processes</b>	Oxygen Generation	
	Water Treatment	HVAC, Fans, Pumps
	Captive Power Plant	HVAC, Fans, Pumps

## General Field Oriented Control Drive C2000 Series Intelligent Sensorless Vector Control Drive CP2000 Series



With our strong position in the industrial automation market, Delta's own brand AC Motor Drives have evolved rapidly. Each Drive series is designed to meet specific application needs. Our AC Motor Drives accurately control speed and torque, smoothly handle an increased load, and provide numerous custom control and configuration operating modes. Our AC Motor Drive product line provides a full range of motor control technologies and is used throughout a wide range of industries, to enhance and improve machine automation.

## Industrial Ethernet Switch IES Series



Delta's Industrial Ethernet Switches feature enhanced hardware design, a user-friendly software interface, packet protection and compatibility with multiple industrial communication standards. With the advantages of high speed, high stability and high compatibility, Delta's Industrial Ethernet Switches help customers construct an industrial Ethernet system that will satisfy their requirements in a wide range of applications. All of Delta's Ethernet products are certified to UL, CE and FCC standards.

## Programmable Logic Controller DVP Series and AH500 Series



Delta's Programmable Logic Controllers (PLCs) offer high-speed, stable and highly reliable applications in all kinds of industrial automation machines. In addition to fast logic operation, bountiful instructions and multiple function cards, Delta's cost-effective PLCs also support various communication protocols. Delta's line of industrial products offer a complete "Delta Total Solution" in the field of industrial automation control.

## Human Machine Interface DOP Series



Delta's DOP series Human Machine Interface (HMI) provides various touch screens with multiple dimensions and colors. It also offers fast and convenient control functions for industrial automation machines. In addition, Delta Windows-based and user-friendly DOPSoft Screen Editor and Programming Software can configure the whole DOP Series. With DOPSoft, users can quickly edit images and graphs and easily set suitable communication protocols. Many applications can be created, edited, downloaded and uploaded.

## Power Quality Solution

In today's metallurgy industry, people are demanding more reliable and stable power supplies with better quality. Power quality has become a key factor for power efficiency. To solve new power quality problems generated at metal production sites, buildings and server rooms, Delta has launched innovative new power quality solution to efficiently solve power quality problems and enhance the operation of metal plants with more efficient production and greater convenience. Delta's Power Quality Solution can gradually replace traditional capacitors to overcome the problems of voltage or current distortion, reactive power impact, and unbalanced loads.



Active Front End  
AFE2000 Series



Active Power Filter  
APF2000 Series



Static Var Generator  
SVG2000 Series





## Temperature Controller DT Series



Delta's DT series Temperature Controllers have fast output response, accurate PID parameter auto-tuning, support the MODBUS communication protocol and have various built-in output types, allowing different systems to quickly reach a stable control status. All series comply with international installation dimensions and CE, UL international safety approvals.

## Industrial Fieldbus Solutions



Delta has developed numerous communication modules and solutions, which can be integrated into various combinations to meet the demands of complex and harsh industrial sites. These solutions offer high speed as well as stable and highly cost-effective choices for small to large system applications. For industrial automation applications of drive, motion and control, we provide general MODBUS RS-232, RS-422 and RS-485 serial communication modules, and offer advanced CANopen, DeviceNet, Ethernet, EtherNet/IP and PROFIBUS fieldbus solutions.

## Industrial Power Supplies



The latest offering from Delta Electronics include the new DVP series, CliQ series, CliQII series, PMC series, and PMT series highly efficient and stable industrial power supplies. These products offer a nominal output voltage of 48V / 24V / 12V / 5V, a wide temperature range from -20°C to +75°C and a minimum holdup time of 20ms. The state-of-the-art design is made to withstand harsh industrial environments. The rugged, ultra-compact case material is shock and vibration resistant according to IEC 60068-2. The power supplies provide overvoltage, overload and thermal protection. The wide input voltage ranges from 85 to 264VAC (1 phase) and 320 ~ 575VAC (3 phase), and the multiple terminals are for fast wiring and easy installation.





Smarter. Greener. Together.

## Industrial Automation Headquarters

### Delta Electronics, Inc.

Taoyuan Technology Center  
No.18, Xinglong Rd., Taoyuan District,  
Taoyuan City 33068, Taiwan  
TEL: 886-3-362-6301 / FAX: 886-3-371-6301

## Asia

### Delta Electronics (Shanghai) Co., Ltd.

No.182 Minyu Rd., Pudong Shanghai, P.R.C.  
Post code : 201209  
TEL: 86-21-6872-3988 / FAX: 86-21-6872-3996  
Customer Service: 400-820-9595

### Delta Electronics (Japan), Inc.

Tokyo Office  
Industrial Automation Sales Department  
2-1-14 Shibadaimon, Minato-ku  
Tokyo, Japan 105-0012  
TEL: 81-3-5733-1155 / FAX: 81-3-5733-1255

### Delta Electronics (Korea), Inc.

Seoul Office  
1511, 219, Gasan Digital 1-Ro., Geumcheon-gu,  
Seoul, 08501 South Korea  
TEL: 82-2-515-5305 / FAX: 82-2-515-5302

### Delta Energy Systems (Singapore) Pte Ltd.

4 Kaki Bukit Avenue 1, #05-04, Singapore 417939  
TEL: 65-6747-5155 / FAX: 65-6744-9228

### Delta Electronics (India) Pvt. Ltd.

Plot No.43, Sector 35, HSIIDC Gurgaon,  
PIN 122001, Haryana, India  
TEL: 91-124-4874900 / FAX : 91-124-4874945

### Delta Electronics (Thailand) PCL.

909 Soi 9, Moo 4, Bangpoo Industrial Estate (E.P.Z),  
Pattana 1 Rd., T.Phraksa, A.Muang,  
Samutprakarn 10280, Thailand  
TEL: 66-2709-2800 / FAX : 662-709-2827

### Delta Electronics (Australia) Pty Ltd.

Unit 20-21/45 Normanby Rd., Notting Hill Vic 3168, Australia  
TEL: 61-3-9543-3720

## Americas

### Delta Electronics (Americas) Ltd.

Raleigh Office  
P.O. Box 12173, 5101 Davis Drive,  
Research Triangle Park, NC 27709, U.S.A.  
TEL: 1-919-767-3813 / FAX: 1-919-767-3969

### Delta Electronics Brazil

São Paulo Sales Office  
Rua Itapeva, 26 - 3º, andar Edifício Itapeva,  
One - Bela Vista 01332-000 - São Paulo - SP - Brazil  
TEL: 55-12-3932-2300 / FAX: 55-12-3932-237

### Delta Electronics International Mexico S.A. de C.V.

Mexico Office  
Gustavo Baz No. 309 Edificio E PB 103  
Colonia La Loma, CP 54060  
Tlalnepantla, Estado de México  
TEL: 52-55-3603-9200

## EMEA

### Headquarters: Delta Electronics (Netherlands) B.V.

Sales: Sales.IA.EMEA@deltaww.com  
Marketing: Marketing.IA.EMEA@deltaww.com  
Technical Support: iatechnicalsupport@deltaww.com  
Customer Support: Customer-Support@deltaww.com  
Service: Service.IA.emea@deltaww.com  
TEL: +31(0)40 800 3900

### BENELUX: Delta Electronics (Netherlands) B.V.

De Witbogt 20, 5652 AG Eindhoven, The Netherlands  
Mail: Sales.IA.Benelux@deltaww.com  
TEL: +31(0)40 800 3900

### DACH: Delta Electronics (Netherlands) B.V.

Coesterweg 45, D-59494 Soest, Germany  
Mail: Sales.IA.DACH@deltaww.com  
TEL: +49(0)2921 987 0

### France: Delta Electronics (France) S.A.

ZI du bois Challand 2, 15 rue des Pyrénées,  
Lisses, 91090 Evry Cedex, France  
Mail: Sales.IA.FR@deltaww.com  
TEL: +33(0)1 69 77 82 60

### Iberia: Delta Electronics Solutions (Spain) S.L.U

Ctra. De Villaverde a Vallecas, 265 1º Dcha Ed.  
Hormigueras – P.I. de Vallecas 28031 Madrid  
TEL: +34(0)91 223 74 20

Carrer Llacuna 166, 08018 Barcelona, Spain

Mail: Sales.IA.Iberia@deltaww.com

### Italy: Delta Electronics (Italy) S.r.l.

Via Meda 2-22060 Novedrate(CO)  
Piazza Grazioli 18 00186 Roma Italy  
Mail: Sales.IA.Italy@deltaww.com  
TEL: +39 039 8900365

### Russia: Delta Energy System LLC

Vereyskaya Plaza II, office 112 Vereyskaya str.  
17 121357 Moscow Russia  
Mail: Sales.IA.RU@deltaww.com  
TEL: +7 495 644 3240

### Turkey: Delta Greentech Elektronik San. Ltd. Sti. (Turkey)

Şerifaii Mah. Hendem Cad. Kule Sok. No:16-A  
34775 Ümraniye – İstanbul  
Mail: Sales.IA.Turkey@deltaww.com  
TEL: + 90 216 499 9910

### GCC: Delta Energy Systems AG (Dubai BR)

P.O. Box 185668, Gate 7, 3rd Floor, Hamarain Centre  
Dubai, United Arab Emirates  
Mail: Sales.IA.MEA@deltaww.com  
TEL: +971(0)4 2690148

### Egypt + North Africa: Delta Electronics

Unit 318, 3rd Floor, Trivium Business Complex, North 90 street,  
New Cairo, Cairo, Egypt  
Mail: Sales.IA.MEA@deltaww.com